

Thermal Video System



*Advanced Thermo*

# TVS-500EX **NEW**



NIPPON AVIONICS CO.,LTD.

# A new stage of infrared thermography now begins

Advanced Thermo **TVS-500EX**



Advanced thermo, TVS-500EX, is an infrared thermography using new Japanese sensor and realizing clearer and higher quality image than before. It is truly an advanced thermography which offers convenient and various functions, and easy operation. In addition, TVS-500EX meets the environmental requirements (compliance to RoHS directive).

# Top level performance in its category

## 0.05°C temperature resolution 1.07mrad spatial resolution

It is equipped with a new Japanese IR sensor realizing ultra high sensitivity and high quality image, and it measures even a micro temperature difference with accuracy.



## Built-in USB link application software

Application software boots up by simple connection to PC.

## Thermal image and visible image can be displayed completely simultaneously.

Our unique transmissive mixing enables to see the background of the thermal image.

The world's first system  
unique to Avio  
(patent pending)

## User friendly design with easy operation

Easy operation is realised with the palm grip of excellent hold feeling and user friendly operation panel.

## Various options to meet different applications

Realtime memory and optional lenses etc are available to satisfy different applications.



# Supporting "visualization" of "heat" from measurement, analysis to report

Avio unique world's first system (patent pending)

## Built-in USB link application software called "Advanced Package"

※As of February 1st, 2007

Advanced Package is designed for USB interface, which is equipped on PC as standard, and it realizes realtime measurement of thermal image and visible image from TVS-500EX. It is also useful in various aspects of measurement such as recording or editing of measured temperature information and images.

The software boots up by simply connecting the USB cable.



Connected with a PC via USB cable.



The application software boots up automatically.



Start measurement.

Various functions are useful in many fields including research and development.

### Realtime display and recording at 1/60 seconds.

High speed display and recording are available with maximum 1/60 seconds for thermal images and maximum 1/20 seconds for visible images.

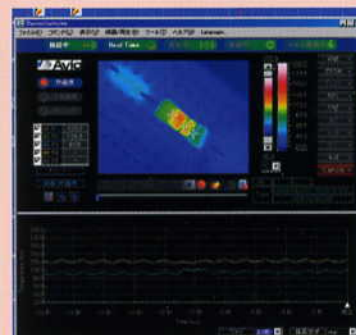

Point temperature trend display ▶

#### Major functions

- Multi point temperature display and trend graph display (maximum 5 points)
- Mixing display of thermal image and visible image
- Interval recording of images
- Changing of displayed temperature range, displayed color and temperature unit
- One shot recording
- CSV file output of point temperature

### Sorting and editing of recorded images

Sorting and editing of recorded realtime images can also be made easily.

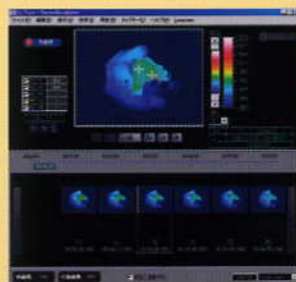

Editing of recorded realtime image can be made.

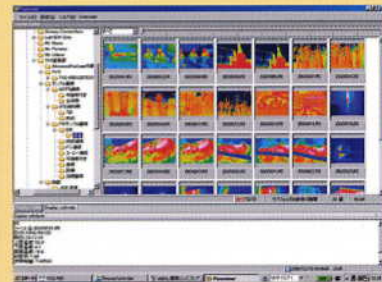

Image sorting and linking with the analytical software can be made easily.

#### Major functions

(Image editing software)

- Conversion of realtime image to a regular thermal image file (selective, totally)
- Point temperature checking and conversion of realtime image file (AVI, WMV)

(File searching software)

- Thumb nail display of recorded thermal images and visible images
- Linking with the optional analytical software, and a function to control image files by date





**NIKON SYSTEMS INC.**

Advanced Package incorporates an advanced image processing software of Nikon Systems Inc.

TVS-500EX



USB link



### Setting and control by a PC



Setting of parameters, such as emissivity, or controlling of the camera itself can be made from a PC. If combined with a remote control unit (option), work efficiency with optional lenses will be substantially improved.

Internet  
E-mail delivery of alarm



### Alarm function

E-mail with thermal image attached can be delivered, and image before alarm can be recorded.

## Analysis is easy using the optional analytical software.

### Thermal image analysis software

(Multi functional software covering from image display to analysis and report writing.)

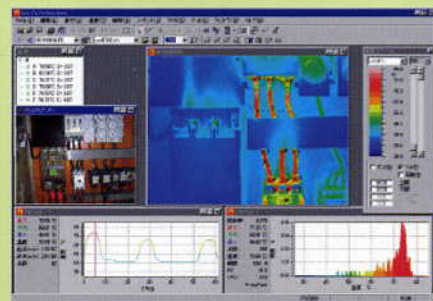

#### File control



#### Profile and histogram

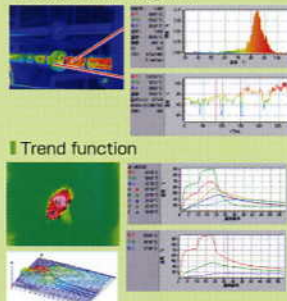

#### Report writing



#### Trend function

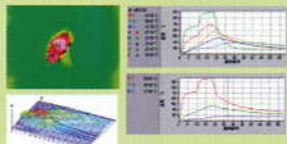

#### Subtraction

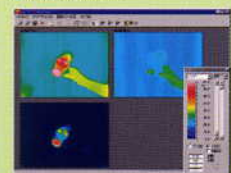

### Major functions

- File control
- Analytical function (temperature measurement, profile, histogram, isotherm, emissivity correction)
- Trend (point, area, profile)
- Subtraction
- Image composition
- 3D display
- Report output
- Various filters
- Data conversion

Depending on the performance of the PC used, above functions may be affected. Please see the last page of this brochure for the details of the software operational environment.



# Variety of functions on the main unit

Thermal image and visible image can be displayed completely simultaneously

**Our unique transmissive mixing function where background of the thermal image can also be seen. (Patent pending)**

Our unique method enables overlapping thermal image and visible image.

The background of the thermal image can be displayed in transmission.

By changing ratio of overlapped thermal image and visible image and easy adjustment of position, TVS-500EX can identify location and understand situation of object easily.



Visible image



Thermal image

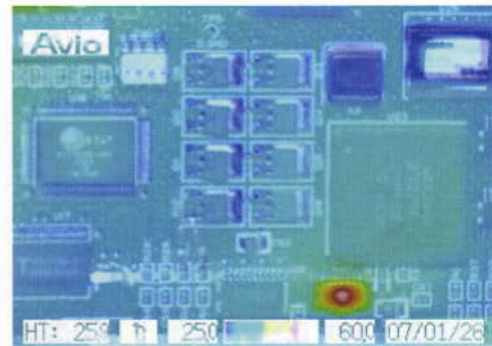

Mixing image

Since visible image is displayed in transmission of thermal image, identification of location can be made easily.

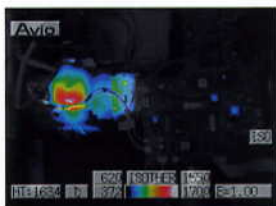

Electronic equipment

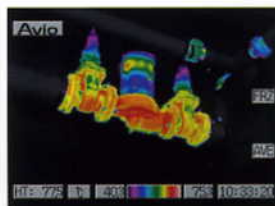

Boiler

Standard functions on the main unit

**In addition, many useful functions for measurement are available as standard.**

Multi point temperature display/multi point emissivity correction

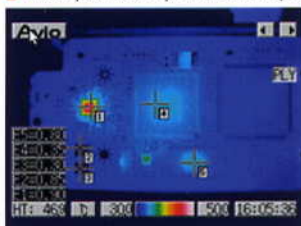

Point temperature can be displayed for up to 5 points, and emissivity of each point can be corrected.

Grid display

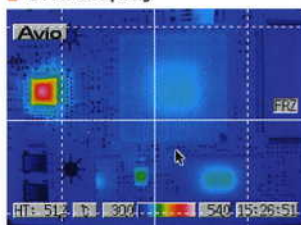

Grids are displayed in 100 pixel spacing. (with standard 22mm lens)

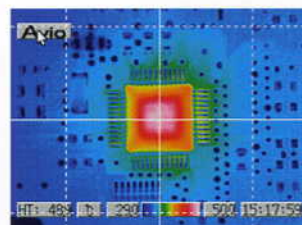

Display with the close-up lens (63μm).

Auto function

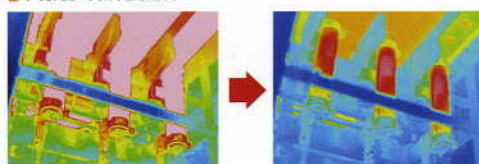

Temperature range suitable for the object can be set in one action.

Maximum (minimum) temperature tracking

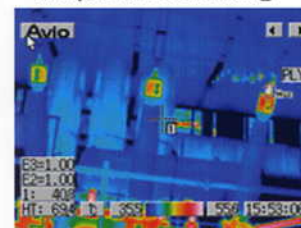

Maximum (minimum) temperature within the screen can be tracked. (area designation and alarm output are possible)

Isotherm

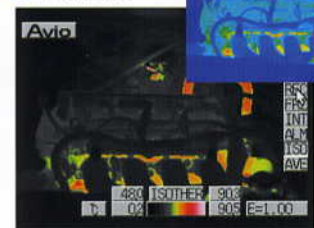

Within the temperature displayed range, the section with a certain temperature range can be highlighted in a different pseudo color.

Zoom function

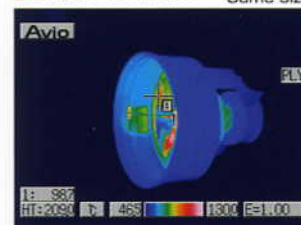

Thermal image can be zoomed (X2, X4). The screen can be scrolled during zoom display.

Same size X2

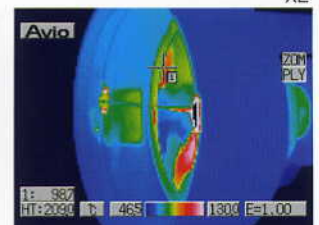

Pointer & Light (laser pointer & LED illuminator), convenient for measurement, is attached as a standard accessory.

Thermal image





## Operability is pursued thoroughly.

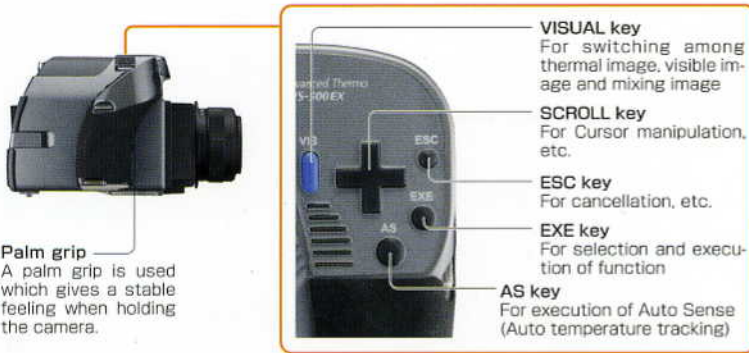

## Variety of interfaces

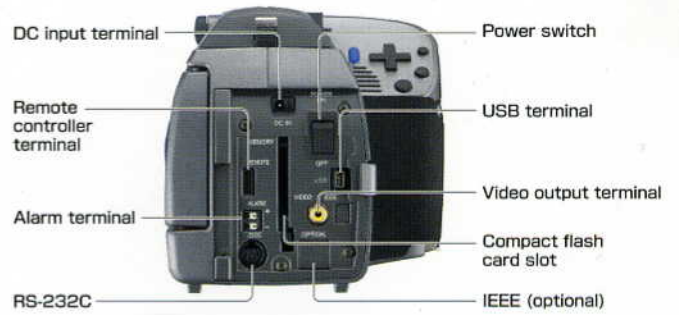

## OPTIONS

### Close-up lens (63 $\mu$ m) TVC-2100UB



Measured temperature range : 0~300°C  
 Measurement distance: 56mm  
 FOV: 20mm(H)x15mm(V)  
 Size:  $\phi$ 66x20.5mm  
 Weight: 90g

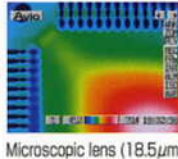
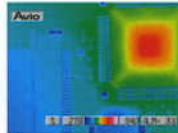
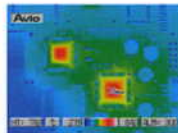

### X2 telescopic lens TVL-2044B



Measured temperature range : -20~500°C  
 Measurement distance : 1200mm or longer  
 FOV: 10'(H)x7'(V)  
 Size:  $\phi$ 84x32.7mm  
 Weight: 170g

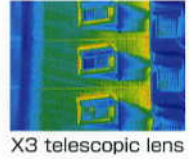
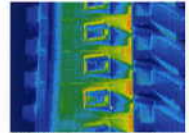
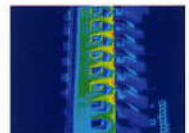

### Microscopic lens (18.5 $\mu$ m) TVM-7025U



Measured temperature range : 30~300°C  
 Measurement distance: 33mm (fixed)  
 FOV: 5.9mm(H)x4.4mm(V)  
 Size:  $\phi$ 66x155mm

### X3 telescopic lens TVL-2066B



Measured temperature range : -20~500°C  
 Measurement distance : 2500mm or longer  
 FOV: 6.4'(H)x4.9'(V)  
 Size:  $\phi$ 126x78.5mm  
 Weight: 550g

### X2 wide angle lens TVL-2011B



Measured temperature range : -20~500°C  
 Measurement distance: 150mm or longer  
 FOV: 39'(H)x29'(V)  
 Size:  $\phi$ 58x32mm  
 Weight: 110g

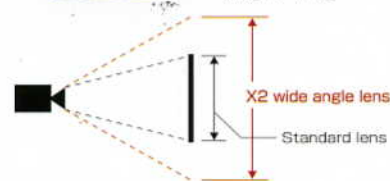

### Exclusive remote controller

The remote controller can be used in direct connection to the camera. (1.5m long cable)



### Long life battery case

The battery case can be used in direct connection to DC input terminal. (Two spare battery packs, sold separately, are required for use.) Approx 4 hours continuous operation.



### Other options

- Filter for high temperature measurement (for 900°C, 2000°C)
- IEEE1394 image transfer kit (for desk top PC, for laptop PC) This is a kit to transfer image via IEEE1394. When it is used, it replaces with the USB interface.
- Carrying case
- Battery pack (for spare)
- Battery charger (for spare)

## Realtime memory (Option)

**Up to 1600 frames of thermal images can be recorded into the memory inside the camera at the maximum speed 1/60 seconds**

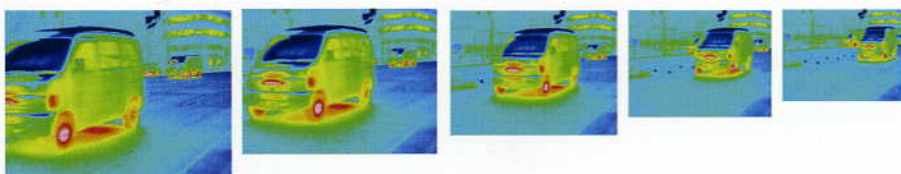

### Specifications

Number of recorded frames	Maximum 400 frames (full size recording) Maximum 1600 frames (reduced size)
Frame time	60fps, 30fps, 20fps, 10fps, 5fps, 2fps, 1fps, 2s
Recording mode	Continuous, alarm, one shot

※When realtime memory is used, it replaces with the USB interface.



# Advanced Thermo TVS-500EX

TVS-500EX		
Measurement range	-40~500°C:Standard ~2000°C (with optional high temperature filter)	
Temperature resolution	Better than 0.05°C with Averaging	
Accuracy	±2°C or ±2% ※1	
Frame time	1/60 seconds	
Detector	Uncooled FPA, 320(H) x 240(V) VOx microbolometer	
Wavelength	8~14μm	
FOV	19.4°(H)x14.6°(V) (with standard 22mm lens)	
Spatial resolution	1.07mrad	
Measurement distance	30cm ~ ∞	
Effective pixels	320(H)x240(V)	
Display	3.5" semi-transmissive color LCD monitor, Inverted display	
Visible camera	640x480	
Functions	Multi point temperature display	5 points
	Multi point emissivity correction	5 points (Back Calculation)
	Mixing Image Display	Mixing of thermal image and visible image display with sequential ration change.
	Maximin temperature position tracking	Yes
	Auto temperature tracking	AS (auto sense), AP (auto point), PPM mode, R&D mode, Medical mode
	Digital zoom	x2, x4 (scroll display, area designation possible)
	Freeze	On/Off
	Isotherm function	Yes
	Grid display	Yes
	Alarm function	Displayed by setting the temperature (single/continuous)
	Signal output	Yes
	Image recording	Interval recording with alarm as a trigger
	Color palette	Rainbow/hot iron/iron bar/white black/black white/contrast
	Image improvement function	Averaging process
Other functions	Emissivity correction, day and time display, battery volume, memo, last memory	
CF Card	Data storage	300/64MB. Up to 512MB. Realtime memory (option) 400 frames (standard), 1600 frames (reduced size) ※2
	Mode	CF format, delete, create directory, file name input, one shot recording, interval recording, one shot playback, gallery display, file name display
	File format	IRI, BMP (thermal image)/JPG (visible image)/BMP (mixing image)/LOG Simultaneous recording of thermal image, visible image, and mixing image.
	Interval recording	3S~23H59m59s (1/60s~ when using optional realtime memory)
Temperature unit	°C/°F/K	
Video output	NTSC or PAL	
PC interface	RS-232C, USB, IEEE1394(option) ※2	
Power	Battery (Li-Ion), AC adapter, Long life battery (option)	
Power consumption	14W	
Battery run time	Approx 2H, approx 4H (when using optional long life battery)	
Operational temperature/humidity	-10~50°C/RH80% or less (no condensation)	
Dimensions	140(H)x140(W)x226(D)mm including protrusions	
Weight	1.9Kg (without battery)	
Environmental protection	IP54	
Shock	30G JISC0041/IEC60068-2-27	
Vibration	3G JISC0040/IEC60068-2-6	

※1 Accuracy applies from -20 to 300°C  
※2 USB, IEEE and realtime memory are exclusive to each other

## Measurement distance and FOV (with standard 22mm lens)

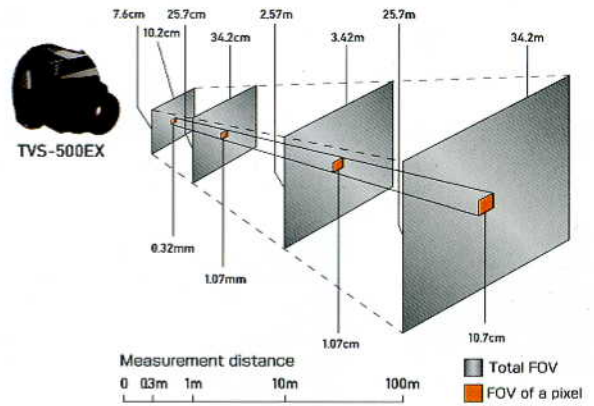

## Operational environment for the USB link software "Advanced Package"

### OS compatibility

OS: Microsoft Windows 2000 SP-4, Microsoft Windows XP SP-2

### PC specifications

- PC-AT compatible
- The above OS shall be preinstalled and USB2.0 interface shall be equipped as standard.
- Pentium M/1.7GHz or better (Pentium 4/2.6GHz or better is recommended)
- RAM: 512MB or more (1GB or more is recommended)
- HDD: A blank space of approximately 1GB or more is required in the HDD. When recording thermal image at 60Fps and visible image simultaneously, 7200rpm or faster 3.5FDD will be required.
- Displayed color: 16 bit color (65536 colors) or more
- Resolution: XGA (1024x768) or better

※This software is dedicated for TVS-500EX, and it cannot be used with other TVS series products. And this software is always sold with the hardware and not sold alone.

※If the USB interface of TVS-500EX is changed to IEEE1394 interface, this software cannot be used.

## Standard configuration

- TVS-500 (with 22mm standard lens) 1ea
- AC adapter
- Battery pack
- Battery charger
- CF card
- Card adapter
- Neck strap
- RS-232C cable
- Operation manual
- Pointer & Light
- USB cable
- CD for application software installation

## ⚠ Precautions for use of this product.

- Please make sure to read the instruction manual carefully before use so that the equipment can be used safely.
- Do not leave equipment in a place where there is water, moisture, steam, smoke, etc. It may cause fire, electric shock or failure of the equipment.
- This company shall not be liable for any incidental damages (loss of business profit, change or loss of data, etc.) caused by the use or non-availability of this product.
- This company shall not be liable for any damages caused by malfunctions due to connection with other equipment or with equipment containing software developed by others.
- This company shall not be liable for any damages caused by using the product in a way other than those explained in the operation manual.
- The specifications and functions described in this brochure may be changed without notice for improvement.
- Company names and product names appearing in this brochure are trade names and trademarks of those companies.
- Windows is a trademark of Microsoft Corporation of the USA registered in the USA and other countries.

●Since the product contains an item under export control, delivery is subject to necessary export licenses by the authorities. It is strictly regulated to export the product to certain area. ●In case of retransfer, resale and/or reexport of the product, prior authorization by the authorities is required.

 **NIPPON AVIONICS CO.,LTD.**

Partner Business Department,  
Industrial Electronic Products Sales Division

URL <http://www.avio.co.jp/>

GOTANDA KOWA BLDG. 1-5 NISHI-GOTANDA

8-CHOME SHINAGAWA-KU TOKYO, JAPAN 141-0031

Phone : 81-3-5436-0625, Fax : 81-3-5436-0639

 **INPROTEC**  
Industrial Process Technologies

Via Bizet, 44/B - 20092 Cinisello Balsamo (MI)

Tel.: +39-02-6608.111 - Fax +39-02-6604.1334

Divisione Infrarosso:

Via Galvani, 2 - 20054 Nova Milanese (MI)

Tel.: +39-0362-365062 - Fax +39-0362-366818

Via Mar della Cina, 193 - 00144 Roma

Tel.: +39-06-5290.487/8 - Fax +39-06-5290.499



ISO 14001  
JSA-040102

ISO 9001  
JSA-1001